

# SEM618B WHEEL LOADER

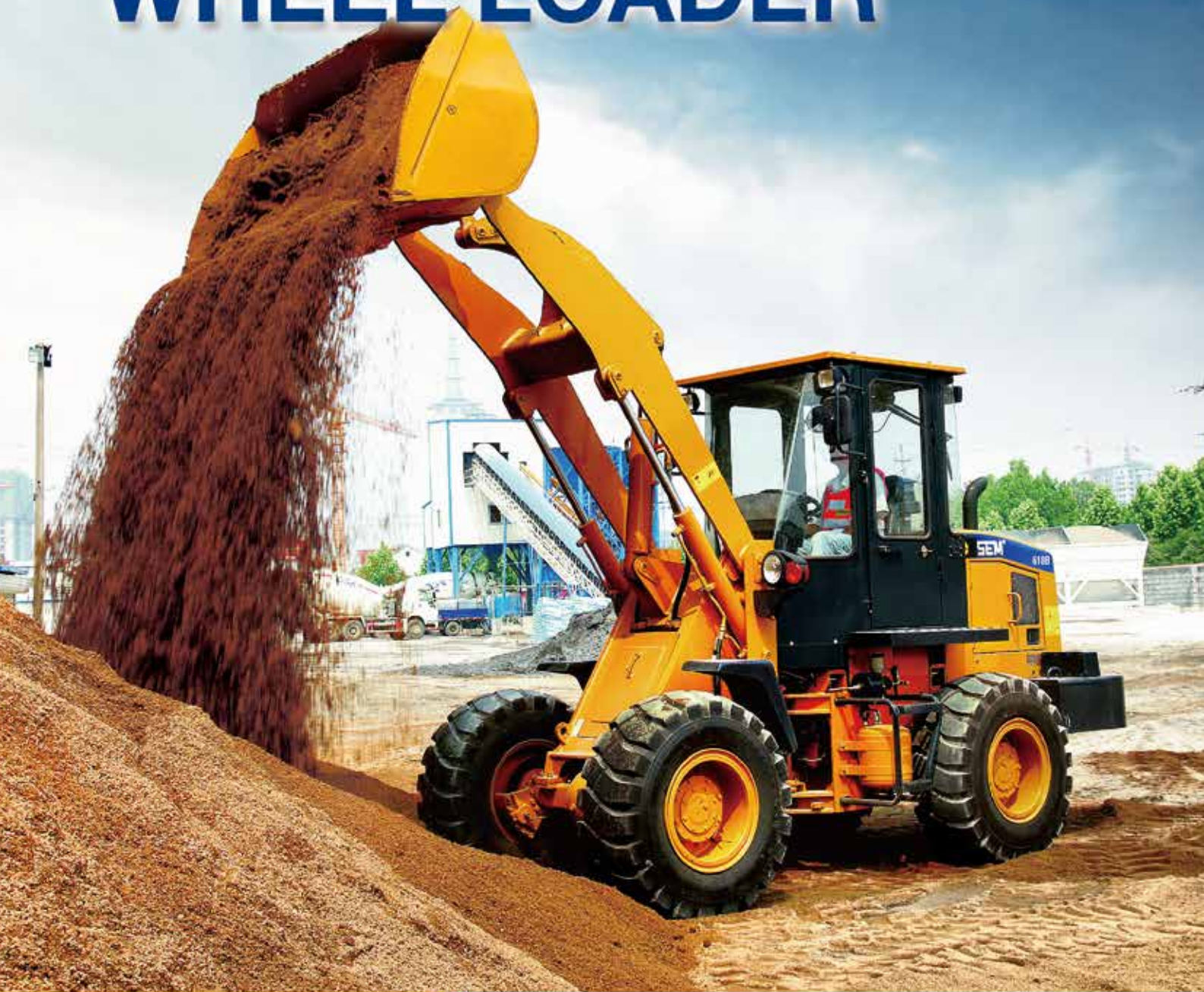

Website <http://www.semmachinery.com>

 **SEM**  
A Caterpillar Brand

# SEM618B Wheel Loader

## Main Specifications

- Rated Load Capacity ..... 1,800 kg
- Operating Weight ..... 5,780 kg
- Bucket Capacities ..... 1.0 m<sup>3</sup>
- Overall Dimensions L\*W\*H\* (mm) ..... 5885×2000×2795

## Engine

- Rated Gross Power ..... 60 kW
- Model ..... Yituo YT4B4
- Peak Torque ..... 320 N.m

## Operating Specifications

- Max. Rimpull ..... 55 kN
- Breakout Force ..... 60 kN
- Full Turn Static Tipping Load ..... 3600 kg

## Hydraulic System

- Pump Displacement-Implement Pump ..... 63 ml/rev
- System Pressure Setting ..... 17 MPa
- Hydraulic Cycle Times :
- Raise ..... 4.37 s
- Dump ..... 0.75 s
- Lower (Empty,Float Down) ..... 2.73 s
- Total ..... 7.9s

## Steering

- Steering Angle Left/Right ..... 35°±1°
- Minimum Turning Radius Over Rear Tire ..... 4229 mm
- Minimum Turning Radius Over Bucket ..... 4980 mm

## Axle

- Rear-Oscillating ..... ± 12°

## Brake System

- Service Brake ..... Dry & Caliper,Air-to-Oil Control
- Parking Brake ..... Drum-Type Shoe Brake

## Transmission

- Type ..... Countershaft Power Shift
- Travel Speed: | ||
- Forward ..... 9.3 km/hr 23.8 km/hr
- Reverse ..... 9.1 km/hr 23.5 km/hr

## Service Refill Capacities

- Cooling System ..... 20 L
- Engine Lubricating Oil ..... 12 L
- Oil for Converter and Gear Box ..... 21 L
- Differentials and Final Drives:
- Front ..... 8 L
- Rear ..... 8 L
- Hydraulic Tank ..... 50 L

## Tires

- Size ..... 16/70-20
- Type ..... Bias
- Layers ..... 14
- Textured Type ..... L3
- Air Pressure ..... Front 0.28 MPa/Rear 0.21 MPa

## Arrangement Drawing

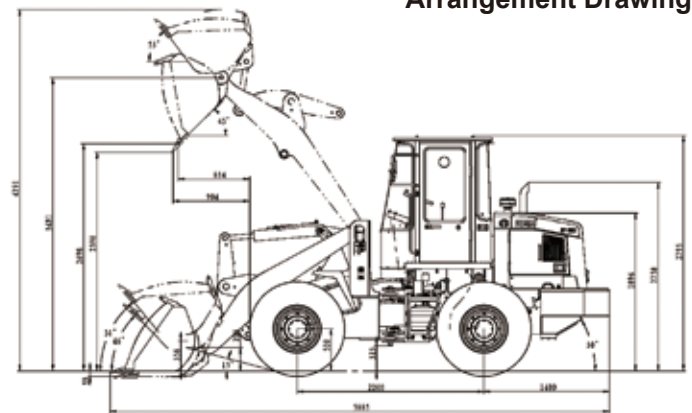

## DEALER NAME

Caterpillar (Qingzhou) Ltd. Address: No.12999 Nanhuan Road,Caterpillar Industrial Park, Qingzhou City,Shandong Province, Zip Code: 262500 P.R.China

© Materials and specifications are subject to change without notice. Featured machines in photos may include optional equipment. See your SEM dealer for available options.

© 2016 Caterpillar (Qingzhou) Ltd. All Rights Reserved. SEM Machinery, SEM, their respective logos, trade dress as well as corporate and product identity used herein, are trademarks of Caterpillar (Qingzhou) Ltd. and may not be used without permission.

Version: September 2016